

An Arduino-Based Intelligent System for Drinking Water Quality Analysis

1st Eugen Marica

Department of Automatic Control, Computers and
Electronics
Petroleum-Gas University of Ploiesti
Ploiesti, Romania
marica_eugen19@yahoo.com

2nd Mihaela Oprea

Department of Automatic Control, Computers and
Electronics
Petroleum-Gas University of Ploiesti
Ploiesti, Romania
mihaela@upg-ploiesti.ro

Abstract – The application of artificial intelligence methods for the environment quality analysis has the potential to provide more efficient solutions than conventional methods use as proved by several research work presented in the recent literature. Among these methods, machine learning techniques were most applied. Also, a knowledge-based approach can provide more informed decisions when the quality of water is analyzed or is predicted. The paper presents a knowledge based approach for the development of an intelligent system for drinking water quality analysis and describes an experimental system based on Arduino that was implemented and tested with success on some types of drinking water.

Keywords–*knowledge-based system; drinking water quality analysis; pH sensor; knowledge modeling; ontology; artificial intelligence; Arduino*

I. INTRODUCTION

The application of artificial intelligence techniques for the improvement of environmental quality is a major issue for increasing the quality of life. In particular, water quality is an essential issue for humans, animals as well as agriculture (e.g. for crops and trees). Moreover, drinking water quality is vital primarily for human health. Thus, it became an important objective for researchers working on sustainable water sources management and on drinking water quality assurance. A representative research work that emphasize the main problems and possible solutions related to drinking water quality analysis is presented in [1].

Water quality is usually evaluated by the water quality index (WQI) and water quality classification (WQC). A recent review of drinking water quality assessment by using WQI is synthesized in [2]. The overview included articles and book chapters published in the period 2011-2021.

There are various WQI types as shown in [3], as for example, CCMEWQI (in Canada), OWQI (in Oregon, USA). WQI evaluates water quality parameters depending on the type of water (as e.g. surface/river/lake water, groundwater, and drinking water) and the water use. There are several classes of parameters that are analyzed, physical parameters

(such as color, turbidity, dissolved solids, suspended solids, total solids, electrical conductivity, and temperature), chemical parameters (such as pH, acidity, alkalinity, dissolved oxygen, biological oxygen, chlorine, and hardness), bacteriological parameters (such as coliform bacteria, algae, and viruses).

The regulations of water quality are set by each country, most of them being aligned to international regulations. The maximum admissible limits and standards for each water quality parameter are established by national legislation, in accordance with international legislation (laws, standards and directives) and with water source and water use (as e.g. human consumption - drinking water, irrigation - water for agriculture).

Various methods for drinking water quality evaluation are discussed in the literature, as shown in [4]. An example of drinking water quality classification given by esthetically parameters identifies the following classes: potable water, palatable water, contaminated (polluted) water and infected water. Each drinking water class has certain limits and values for the parameters that are analyzed. The literature reported different methods for the evaluation of water quality (including drinking water) among which those based on artificial intelligence (AI) proved to be more efficient. Examples of such methods include machine learning (ML) methods (such as artificial neural networks, deep learning, decision trees) and knowledge-based methods (as e.g. rule-based, fuzzy rule-based).

In this paper it is described a knowledge-based approach for drinking water quality analysis that uses an ontology for domain knowledge modelling and a knowledge base with rules that analyze a set of drinking water quality parameters and some heuristic rules that make water classification. The knowledge-based approach was implemented for an intelligent system based on Arduino Uno and Raspberry Pi that was developed for the analysis of drinking water quality [5]. The system was experimented on different types of drinking water.

The paper is organized as follows. Section II briefly describes water quality analysis and presents an

overview of some existing systems reported in the literature that use artificial intelligence-based methods. The knowledge-based approach for drinking water analysis is introduced in section III. Section IV presents the experimental intelligent system based on Arduino and Raspberry Pi that was developed and discusses the results obtained by using this system. The main conclusion and some future work are presented in the last section of the paper.

II. LITERATURE REVIEW

The evaluation of drinking water quality is made according to the national specific standards that in case of EU countries are aligned with the EU Drinking Water Directive DWD 2020/2184 [6]. In Romania it is used the Ordinance no 7/2023 [7].

Different types of technologies were or can be applied, for monitoring water quality (e.g. smart sensing, smart networks, IoT, digital twins, cloud), and for analyzing the quality of water (e.g. artificial intelligence and machine learning techniques).

The analysis of drinking water quality (DWQ) can be performed on drinking water samples or in real time for the drinking water monitoring network (e.g. in urban areas). Various types of sensors can be used for monitoring water quality parameters (e.g. pH sensor, turbidity sensor, hardness sensors etc).

Most of the research work reported in the area of water quality analysis use the water quality index as a mean to evaluate the quality of water, in particular, of drinking water (as e.g. tap water, bottled water etc).

More than 20 articles published in the recent years with research work performed in different areas worldwide (Europe, USA, Australia, Africa, South America) or reviews were analyzed. A selection of papers is briefly described as follows.

A multi-layer perceptron method (MLP) is applied in [8]. Several algorithms were tested such as multi-layer regression (MLR), MLP, artificial neural networks (ANN), support vector machine (SVM) and the best algorithm proved to be the MLR-based WQI model. The research work performed an evaluation of water quality based on artificial intelligence techniques for the potential use of surface water of Aksu Creek (Turkey) that flows into the Black Sea for drinking and irrigation purposes.

A research work that performed the assessment of drinking water sources quality in the highlands of Ethiopia, based on 9 physicochemical parameters and 2 bacteriological parameters is presented in [9]. The selection of the parameters was made according to the specificity of water sources. The esthetic parameters that were analyzed were taste, color and odor. A WQI tool was used, namely Weighted Arithmetic WQI (WAWQI). The main conclusion was that the tap water is the only free source of bacteriological contaminants.

A real time and low cost drinking water quality monitoring and contamination detection system based on smart sensors is introduced in [10]. The system based on ZigBee protocol was designed for use in

water distributed mains. The parameters that are monitored include: pH, temperature, conductivity, turbidity and oxidation reduction potential.

An intelligent water quality monitoring system based on IoT and machine learning is described in [11]. The system was applied in tourist regions of Bangladesh for drinking water safety. An ANN gave best results among the classification algorithms that were experimented. The system monitors four parameters: temperature, turbidity, pH and total dissolved solids (TDS).

A Raspberry Pi smart sensing platform developed for real time drinking water quality monitoring is presented in [12]. The classification of water quality was made by using Fuzzy Inference System (FIS) and the Python programming language was used for data acquisition and analysis. The monitoring system uses a multi-sensor array. The fuzzy approach [13] was implemented online. The main advantage of a FIS technique is that absorbs vagueness related to the observed parameters and knowledge is given under the form of linguistic rules. The water was categorized in different classes such as water good for irrigation, for drinking, and for bathing. The authors uses the Mamdani FIS model that provided more accurate results than the Takagi-Sugeno model. The parameters that were analyzed are: temperature, pH, electrical conductivity (EC), oxidation relation potential (ORP), and dissolved oxygen (DO).

A review of eight systems recently reported is synthesized in [14]. The authors proposed an efficient real time IoT based smart water quality continuous monitoring system that use Arduino ATMEGA 328 microcontroller and wireless communication. A cloud server performed the analysis of the monitored parameters.

A smart and efficient system based on long-range IoT for water quality monitoring is presented in [15]. The system uses a LoRa (long range) network server and has a microcontroller ATmega 328P-AU, monitoring pH and turbidity, parameters that can be assessed by using online equipment. A cloud service (Antares database) is used for storing data sent via Android.

The results of hydrochemical characteristics evaluation for groundwater in a region from China (Lianhuashan) are discussed in [16] and assessed for drinking purposes. The authors used WQI and the Synthetic Pollutin Index (SPI) with geospatial tools for the evaluation of water suitability for human consumption.

A ML-based intelligent system for drinking water quality assessment is introduced in [17]. The system provides in real time reports and consumer awareness and is based on the WaterNet data set. The monitored parameters are: temperature (measured by a real time sensor), turbidity, pH, some chemical concentration. The ML algorithms that were tested are: Long Short Term Memory (LSTM), Convolutional Neural Network (CNN), Random Forest (RF), Gradient Boosting Machine (GBM) and Stacked Denoising Autencoders (SDAE). The detection accuracy that was reported in this research work is greater than 95%.

A network architecture for monitoring and assessment of water quality for drinking and irrigation is described in [18]. The authors used a LoRa based monitoring network and applied three ML models, RF, Logistic Regression (LR), and SVM for water classification.

In [19] different types of water quality index were used for the assessment of drinking water sources of Finote Selam town in Ethiopia. Examples of WQI that were computed are: WAWQI, CCMEWQI and Nemerow's pollution index (NPI). The author used a set of 12 water quality parameters selected from the physical, chemical and bacteriological parameters. The better results were given by WAWQI.

A recent research work that performed water quality assessment for human consumption in a city from Brazil, Manicoré-am, is discussed in [20]. The authors made a survey of semi-artesian wells supplying the city analyzing selected physical, chemical and bacteriological parameters.

Another recent research work that made an assessment of groundwater quality for drinking water use in different regions from Africa, Algeria, Kenya, and Zambia is reported in [21]. The authors computed WQI based on a set of physical, chemical and bacteriological parameters that were selected by taking into account the specific pollutants for each region.

A recent review performed in USA (Arkansas) related to a long-term public perception of drinking water quality was reported in [22]. After a proper selection, 64 articles were included in the analysis, referring to tap water, filtered water, bottled water, spring water and well water. The research study took into account organoleptic characteristics such as taste, color, smell. One of the conclusions of this review was that people have more trust in bottled water. In order to increase people trust in other types of drinking water (such as tap water, filtered water, spring water etc) it is important to improve the infrastructure and to increase transparency community trust.

A study of drinking water quality analysis performed in some localities from South East Romania, in Galati, Braila, Buzau and Vrancea counties is described in [23]. The analysis included different types of drinking water, tap water, filtered tap water, fountain and well water, spring water, for each water sample a set of chemical and physical parameters being analyzed with CONSORTC-862 multiparameter instrument. One of the conclusion of this study was that the drinking water is intensely mineralized.

A research work on drinking water analysis for metal contaminants is discussed in [24]. The study was performed in 2015 for 75 wells from the Dambovit County, Romania. The authors applied Principal Component Analysis (PCA) in order to determine the most influent parameters.

In [25] it is tackled continuous monitoring and warning of dynamic changes in the quality of water by using a high-frequency intelligent network of sensors. The authors used cloud computing, IoT and machine learning based data analytics.

A review of key sensing technologies applied to surface and drinking water quality monitoring and analysis is presented in [26]. The performance of different types of sensors (potentiometric, amperometric, interdigitated, chemiresistive, multisensors and biosensors) were analyzed from the viewpoint of material used at their fabrication, sensitivity and response time. A special focus was made on the reusability of sensors and their sustainability.

A review of annual drinking water quality reports and data for regional and remote locations in Australia is described in [27]. The authors performed an analysis that reveals the gaps in the policy adopted by different regions related to the Australian Drinking Water Guidelines use.

TABLE I presents a synthesis of literature review for selected papers.

TABLE I. LITERATURE REVIEW – SYNTHESIS

Crt. No.	DW Quality		
	Reference, Year, Country	WQI and other characteristics	Method, AI, ML, IoT, Cloud
1.	[8], 2024, Turkey	WQI based on ML algorithms	AI, ML, MLR, MLP-ANN, SVM
2.	[9], 2022, Ethiopia	WAWQI	n/a
2.	[10], 2019	Real time, low cost ZigBee protocol	n/a
3.	[11], 2025, Bangladesh	Real time, ESP32 microcontroller, low cost sensor	AI, ML, ANN, IoT
4.	[12], 2019, India	Raspberry Pi, real time, multi-sensor array	AI, FIS
5.	[14], 2021, a review	Real time, controller (Arduino ATMEGA 328), smart sensors	IoT, Cloud
7.	[15], 2024, Indonesia	controller ATMEGA 328P-AU, smart sensors, smartphone Android	IoT, LoRa network server, Cloud service (Antares)
8.	[16], 2021, China	WQI, SPI, geospatial tools	n/a
9.	[17], 2025	Real time, smart sensors, mobile phone	AI, ML, LSTM, CNN, RF, GBM, SDAE
10.	[18], 2022, South Africa	Real time, a network (hierarchical cyber physical network), Arduino, Raspberry Pi	AI, ML, RF, LR, SVM, LoRa, Cloud server
11.	[19], 2025, Ethiopia	WQI (WAWQI, CCMEWQI), NPI	n/a
12.	[20], 2025, Brazil, Manicoré-am	Water quality assessment of semi-artesian wells supplying the city	n/a

Crt. No.	DW Quality		
	Reference, Year, Country	WQI and other characteristics	Method, AI, ML, IoT, Cloud
13.	[21], 2025, Africa: Algeria, Kenya, Zambia	WQI	n/a
14.	[22], 2025, USA, Arkansas, a review	tap water, filtered water, bottled water, spring water, well water	n/a
15.	[23], 2020, Romania, Galati, Braila, Buzau and Vrancea counties	tap water, filtered tap water, fountain and well water, spring water, CONSORTC-862 multiparameter instrument	n/a
16.	[24], 2016, Romania, Dambovita County	Drinking water analysis related to metal contaminants	Statistical analysis, PCA
17.	[25], 2024, India	Continuous monitoring and warning of dynamic changes in the quality of water	a high-frequency intelligent network of sensors, IoT, AI, ML, cloud computing
18.	[26], 2021	Review of key sensing technology for surface and drinking water quality monitoring and analysis	n/a
19.	[27], 2022, Australia, review	Analysis of annual drinking water quality reports and data for regional and remote locations in Australia	n/a

Various AI techniques were applied to the analysis of drinking water quality (machine learning, artificial neural networks, deep learning, and other machine learning techniques). The literature review revealed that in the last five years the drinking water quality analysis was performed by using modern techniques such as AI and ML-based techniques (e.g. ANNs, RF, LR, SVM, LSTM, FIS etc), Cloud services, as well as more efficient real time systems for monitoring and analysis based on intelligent networks, smart sensors, IoT, microcontrollers, smart phones and different means for communication (such as Wi-Fi and LoRa). Among machine learning techniques, ANNs provided better accuracy of the results. Another important remark is that knowledge based approaches were not enough investigated. One of the used method is that of fuzzy rules derived by FIS.

The approach that is described in this paper emphasizes the use of a knowledge base that incorporates rules derived from the standards of drinking water quality as well as rules for computing different types of WQI formula and heuristically rules derived from the human experts' experience in drinking water quality analysis. In the next sections it

is presented in detail the knowledge-based approach for drinking water quality analysis and the integration of the knowledge base in an experimental system based on Arduino UNO and Raspberry Pi.

III. THE KNOWLEDGE-BASED APPROACH FOR DRINKING WATER QUALITY ANALYSIS

A. Methodological Guidelines

The main steps of the methodology that is followed by the proposed knowledge-based approach for drinking water quality analysis are given below.

Domain of expertise: drinking water quality analysis

Input: the domain of expertise;

Output: knowledge base and intelligent experimental system for drinking water quality analysis

- 1) Domain conceptualization - ontology development;
- 2) Knowledge base development for drinking water quality analysis;
- 3) Design an experimental system based on micro-controllers such as Arduino, and a set of smart sensors for drinking water quality monitoring and analysis;
- 4) Implement the experimental system and integrate the knowledge base developed in step 2);
- 5) Test and validate the experimental system for a set of drinking water quality samples.

In the next subsections it is detailed the ontology and the knowledge base, while information related to the experimental system are given in the next section.

B. The Ontology

The main concepts from the domain of expertise were identified and were included in the **Onto_DWQ_preliminary_version_1.0.owl** ontology that was implemented in Protégé [28], a free open source Java-based editor. A screenshot with selected concepts from the ontology is given in Figure 1.

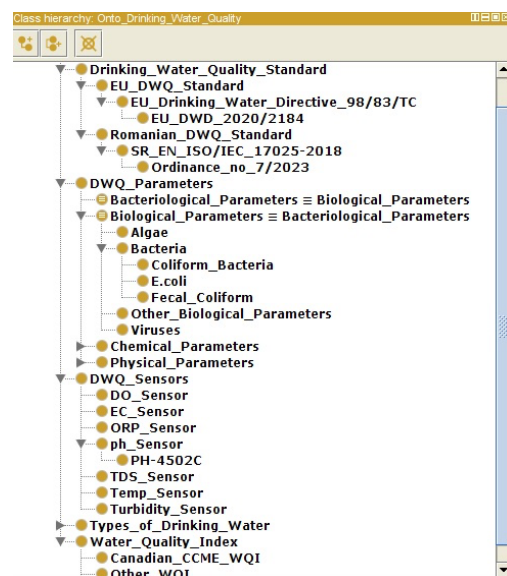

Figure 1. The ontology for drinking water quality assessment (Protégé) - selected terms

The taxonomy of the physical parameters that are used for drinking water quality assessment is shown in Figure 2. It can be noticed that the synonyms are equivalent terms in the ontology. An example is given by odor and smell which are synonyms.

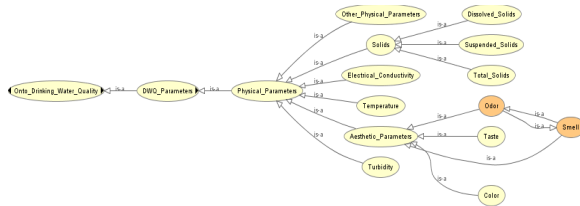

Figure 2. The taxonomy of physical parameters for drinking water quality assessment (in OWL Viz)

The taxonomy of the chemical parameters that are used for drinking water quality assessment is shown in Figure 3. The most used chemical parameters were included.

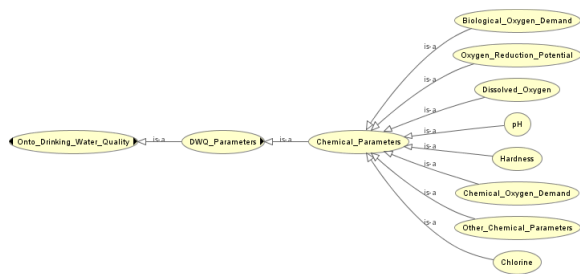

Figure 3. The taxonomy of chemical parameters for drinking water quality assessment (in OWL Viz)

A screenshot with the classification of drinking water types is given in Figure 4.

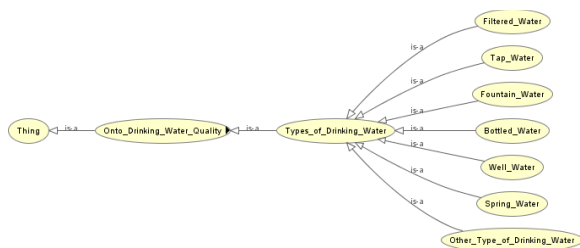

Figure 4. The classification of drinking water types (in OWL Viz)

A classification of drinking water pollution sources is shown in Figure 5.

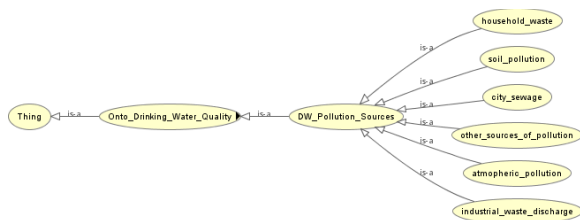

Figure 5. The classification of drinking water pollution sources (in OWL Viz)

Finally, a taxonomy of the sensors used for drinking water quality monitoring and analysis is given in Figure 6.

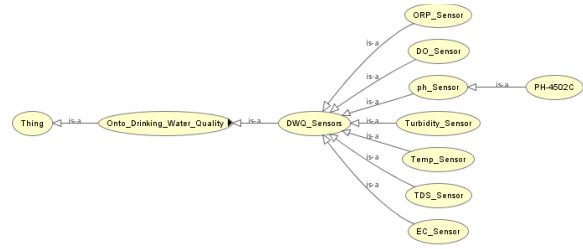

Figure 6. The taxonomy of the sensors used for drinking water quality monitoring and analysis (in OWL Viz)

The concepts that were defined in the ontology *Onto_DWQ_preliminary_version_1.0.owl* are used in the knowledge base of the intelligent system, for example, in the premise or conclusion of the rules and in facts.

C. The Knowledge Base

The knowledge base (KB) has three main groups of rules, standard of drinking water quality rules for each parameter (physical, chemical and biological), rules for WQI computing, and heuristic rules derived by expert humans from their experience.

In Figure 7 it is depicted a part of the analysis tree for the problem of drinking water quality analysis by taking into account three types of parameters, physical, chemical and biological (or bacteriological). Each parameter that is analyzed has a value (usually, a numerical one that is measured with a specific type of sensor), and a symbolic value that is derived based on the limits imposed by the standard of drinking water quality. For example, pH is measured with a specific pH sensor and the value that is analyzed is pH_V, while the symbolic value (which is a linguistic term) is pH_S.

The WQI can be computed with rules provided by experts in the domain. The values for the drinking water quality, i.e. the DWQ goal variable, can be good, very good, poor, very poor etc.

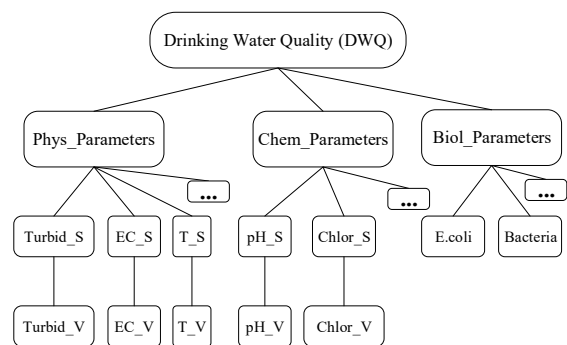

Figure 7. The DWQ analysis tree (selected parameters)

Among the physical parameters, the aesthetical parameters were identified, i.e. color, odor (smell) and taste of water. The analysis tree for these parameters is depicted in Figure 8.

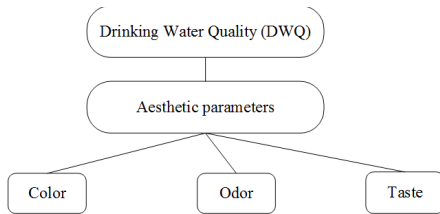

Figure 8. Aesthetical parameters analysis tree

A full analysis of drinking water quality will take each physical, chemical and biological parameter and will compare its value with the standard's limit. The knowledge base refers to a part of the parameters, as follows: two physical parameters (turbidity and an aesthetical parameter, color) and two chemical parameters, pH and residual chlorine. Also, in the experiments we have used the odor and taste aesthetical parameters. All aesthetical parameters have a symbolic value, being linguistic terms.

For each parameter that is analyzed by the intelligent system it was identified the domain of values according to the drinking water quality standard.

1) The domain of pH values:

$$D(\text{pH_V}) = \{0 - 14\}$$

2) The domain for the symbolic values of pH:

$$D(\text{pH_S}) = \{\text{acidic, neutral, alkaline}\}$$

3) The domain of turbidity values:

$$D(\text{Turbid_V}) = \{\leq 1.0 \text{ NTU}\}$$

4) The domain for the symbolic values of turbidity:

$$D(\text{Turbid_S}) = \{\text{high, average, low}\}$$

5) The domain of residual chlorine values

$$D(\text{Chlor_V}) = \{\geq 0,1 - \leq 0,5\}$$

6) The domain of residual chlorine symbolic values:

$$D(\text{Chlor_S}) = \{\text{high, average, low}\}$$

7) The domain of values for color:

$$D(\text{color}) = \{\text{very_dark, dark, light, very_light}\}$$

8) The domain of values for the goal variable, drinking water quality:

$$D(\text{DWQ}) = \{\text{very_good, good, poor, very_poor}\}$$

A set of rules from KB refers only to the pH value that is measured in order to classify the water in three types of water, acidic, alkaline and potable.

Rule_1_pH:

IF pH < 6.5 **THEN** water_type = acidic.

Rule_2_pH:

IF pH > 8.5 **THEN** water_type = alkaline.

Rule_3_pH:

IF pH_V >= 6.5 **AND** pH_V <= 8.5

THEN water_type = potable.

Examples of heuristic rules are given below:

RULE 1:

IF pH_V < 6.5 **AND** Turbid_S = high **AND**
Chlor_S = average **AND** color = dark

THEN

DWQ = poor;

RULE 2:

IF pH_V < 6.5 **AND** Turbid_S = high **AND**
Chlor_S = high **AND** color = very_dark

THEN

DWQ = very_poor;

RULE 3:

IF pH > 8.5 **AND** Turbid_S = high **AND**
Chlor_S = low **AND** color = dark

THEN

DWQ = poor;

RULE 4:

IF pH_V >= 6.5 **AND** pH_V <= 8.5 **AND**
Turbid_S = low **AND** Chlor_S = low
AND color = light

THEN

DWQ = very_good;

RULE 5:

IF pH_V >= 6.5 **AND** pH_V <= 8.5 **AND**
Turbid_S = average **AND** Chlor_S =
low

AND color = light

THEN

DWQ = good;

A set of rules are derived from the EU standard for drinking water quality [6] for each parameter that is monitored, microbiological, physical or chemical that has a correspondence in the Romanian legislation [7]. For example, residual chlorine (Chlor_V) should be in the interval [0.1, 0.5], for potable water, where the measure unit is mg/l, and total hardness should be >= 5 German degrees. The aesthetical parameters, odor (smell) and taste, as well as turbidity should be acceptable for human consumers and with no abnormal changes.

The knowledge base that was developed was integrated in the intelligent experimental system that was developed for drinking water quality analysis. Details are given in the next section.

IV. THE EXPERIMENTAL SYSTEM

According to the methodology described at the beginning of section III, it was designed an intelligent system based on a microcontroller and a microprocessor that integrates the knowledge base that was developed. The block diagram of the experimental system is presented in Figure 9.

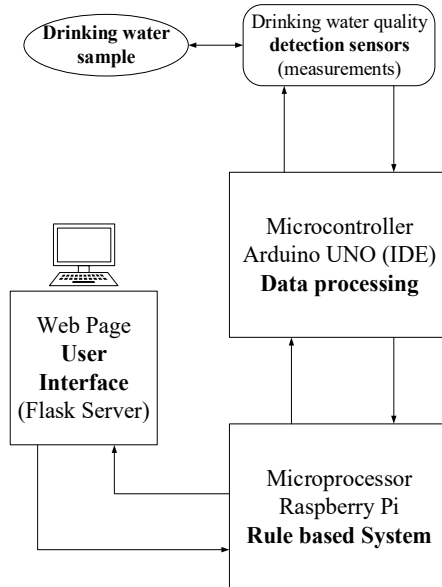

Figure 9. The block diagram of the experimental system

The system has a modular structure and has four main components: a sensing module (which in this first version of our experimental system has a pH sensor), an Arduino UNO microcontroller [29] for data processing (e.g. data filtering, data cleaning), a Raspberry Pi microprocessor [30] that performs data analysis based on the knowledge base that it incorporates, and the user interface which is a web page on a Flask server that is supported by the Raspberry Pi microprocessor. Also, the drinking water sample that is analyzed was added to the system.

A. The Description of the Experimental System

In the development of our experimental system we have used several hardware components as well as software tools, as follows. Thus, we have used an Arduino UNO microcontroller, the Arduino IDE for programming the Arduino UNO microcontroller, the Python programming language, and PySerial library, the Flask web server, HTML, Raspberry Pi 3 Model B+ microprocessor, PH-4502C pH sensor [31], and the PH Electrode Sensor Probe.

The experimental system integrates Arduino IDE for programming the Arduino Uno microcontroller as it is a popular and easy to use development platform for Arduino including all functions that are necessary to write, load and debug the code for Arduino microcontroller. The intelligent system uses Arduino IDE to configure the pH sensor, to read the measured values and to send these values to Raspberry Pi microprocessor through a serial connection [29].

A code sequence for Arduino Uno related to pH sensor use is given below:

```
// analogic pin to which is connected the pH sensor
#define SensorPin A0
unsigned long int avgValue; // average value
float b;
int buf[10], temp;
void setup()
{
  pinMode(SensorPin, INPUT);
  Serial.begin(9600);
}
void loop() {
  for (int i = 0; i < 10; i++)
  {
    // read 10 values for an average value
    buf[i] = analogRead(SensorPin);
    delay(10);
  }
  for (int i = 0; i < 9; i++)
  { // sort the values that were read
    for (int j = i + 1; j < 10; j++)
    {
      if (buf[i] > buf[j])
      {
        temp = buf[i];
        buf[i] = buf[j];
        buf[j] = temp;
      }
    }
  }
  avgValue = 0;
  // compute the average of central value
  // (without the smallest and the highest two values)
  for (int i = 2; i < 8; i++)
    avgValue += buf[i];
  float pHValue = (float)avgValue*5.0/1024/6;
  // convert the analogic value at voltage
  pHValue = 3.0 * pHValue + 0.5;
  // formula for voltage conversion in pH
  // (needs calibration)
  Serial.print("pH: ");
  Serial.println(pHValue);
  delay(1000);
}
```

The communication management and data processing was done in Python, a flexible programming language. It was used the PySerial library which offers a simple and efficient interface for

serial communication. Also, through PySerial it was set the connection between Arduino and Raspberry Pi, and it were intermediated data storage and pH sensor data read, processing and display.

It was imported the PySerial library by using the code sequence 'import serial'. This library is essential for serial communication management in Python. It was added the serial connection configuration with the code 'ser = serial.Serial('/dev/ttyUSB0', 9600)'. This instruction makes the link with the connection port of Arduino Uno towards Raspberry Pi. "USB0" can be a different one depending on the port in which it is introduced the power cable of Arduino Uno microcontroller.

The `read_ph()` function uses a while iteration to wait until data is available in the serial buffer (`ser.in_waiting`) as can be seen in the following code sequence:

```
def read_ph():
    while ser.in_waiting == 0:
        pass # wait until data is available
        ph_value=ser.readline().decode('utf-8').strip()
    return ph_value
```

Once data is available, the function read a whole line from the serial connection by using `ser.readline()`. Then, the data that was read is decoded from the UTF-8 format and is cleaned of white spaces by using the `strip()` function, in order to eliminate any characters of newline or additional spaces. The function returns the value of pH that was measured by the pH sensor. The code sequence is given below.

The use of `read_ph()` function was made in the code sequence through the endpoint `get_ph`. When this route is accessed, the `get_ph()` function call the `read_ph()` function in order to obtain the pH value from Arduino.

```
@app.route('/get_ph')
def get_ph():
    ph_value = read_ph()
    # Add the pH value and timestamp in values
    history
    ph_history.append({"ph":ph_value,"datetime":
datetime.datetime.now().strftime("%Y-%m-%d
%H:%M:%S")})
    return jsonify(ph=ph_value)
```

The pH value with the current timestamps is added to the `ph_history` list in order to keep the values history. Then, the function return the value of pH in JSON format that will be displayed in the web interface.

The Arduino UNO microcontroller was chosen due to its versatility and its easy use. Arduino UNO is one of the most popular microcontroller from the Arduino series, having an ATmega328P microcontroller. This

microcontroller has 14 digital pins for input/output (from which 6 can be used as PWM output), 6 analogical input, a quartz crystal of 16 MHz, a USB connection, a power connector, a ICSP header and a reset button. Arduino UNO was used to read data from the pH sensor and to send them to the Raspberry Pi microprocessor through serial communication [29].

For the web server it was selected a Flask server, with a minimal web flexible framework for Python. Flask is an ideal choice when developing small and medium size web applications, due to its simplicity and modularity. The Flask server manages the client requests, provides the web pages of the application and communicates with Arduino to obtain and display the pH values in real time. Flask facilitated the rapid and efficient development of the web application.

The pH sensor that is used by the intelligent system is a PH-4502C sensor [31] connected to Arduino Uno as follows: VCC to 5V pin of Arduino, GND to GND pin of Arduino, PO (analogic output) at A0 pin of Arduino and USB connection for serial communication with PH-4502C.

The start web page of the experimental system is shown in Figure 10.

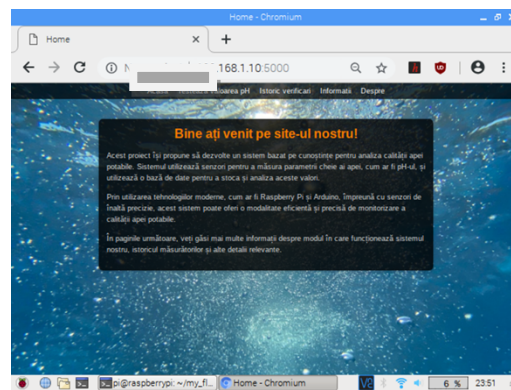

Figure 10. The main page of the intelligent system

B. Experiments and Discussion

A set of experiments were performed on different types of water, the majority of them on drinking water. Figure 11 shows the setup of the experimental system when testing a sample of tap water.

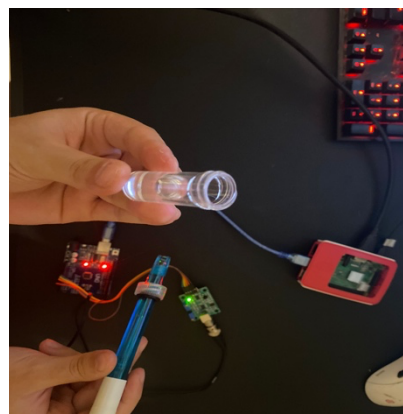

Figure 11. The experimental system tests a tap water sample

A brief explanation of the main steps of the setup done before the water samples are tested is given as follows.

In order to run the application of the experimental system it is opened the control panel through Raspberry Pi with the following commands:

```
cd my_flask_app
python3 app.py
```

Thus, the Flask web server was opened and it is activated the connection to the web page with the IP address https://192.168.1.10:5000/test_ph, which is the local address of Flask server that run on Raspberry Pi. Figure 12 shows the configuration of the application as explained.

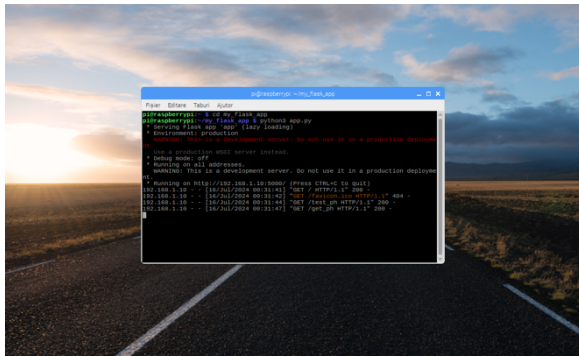

Figure 12. Configuring the application of the experimental system

The experimental results that were obtained for several experiments that were run on different types of drinking water samples are shown in TABLE II. The experiments were extended to other types of water as for example, bottled water and water from pool.

Eight experiments were performed, six on samples of drinking water (tap water and bottled water) and two on water from two pools. A screenshot with the analysis result of the experiment on tap water is shown in Figure 13. The parameters that were analyzed in the experiments performed on drinking water samples are pH, color, odor (smell), taste and turbidity. Only one parameter, pH, was measured while the other parameters were treated as aesthetic parameters and they were set with symbolic values according to the observations (color, Turbid_S) and determinations (odor, taste, Chlor_S) done by the person that performed the analysis. Thus, the values that were obtained for the aesthetic parameters of drinking water samples are:

color = very_light, odor = acceptable,

Turbid_S = low, taste = acceptable,

Chlor_S = low (this last parameter was determined when the drinking water sample was tasted and smelled).

For each water sample 5 measurements were made for pH value in order to assure the data consistence and precision. Moreover, a comparison of the recorded values with the reference values was done in order to evaluate the system's performance.

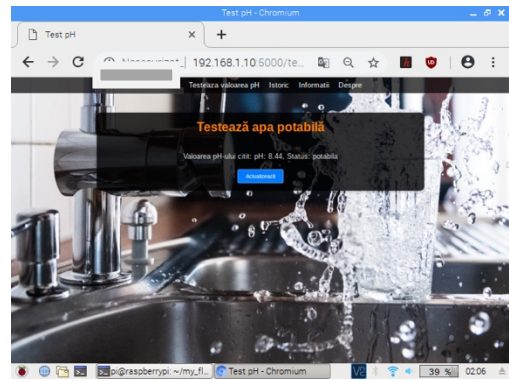

Figure 13. Example of intelligent system run for a tap drinking water sample

TABLE II. EXPERIMENTAL RESULTS – DIFFERENT TYPES OF WATER

Exp No.	DWQ Analysis Results		
	pH value	DWQ	Type of water
1.	8.10	Neutral (potable water)	Tap water Ploiești city
2.	6.48	Acidic	Pool water Ploiești city
3.	6.42	Acidic	Pool water Urlați city
4.	8.57	Alkaline	Bottled mineral water Borsec
5.	7.23	Neutral (potable water)	Bottled water Aqua
6.	7.99	Neutral (potable water)	Bottled water Borsec
7.	7.86	Neutral (potable water)	Bottled water Bucovina
8.	9.48	Alkaline	Bottled mineral water Bucovina

The experimental results confirmed the system's efficiency in monitoring and analyzing the drinking water quality contributing to the human consumers' health and safety.

The main advantage of the experimental intelligent system comparing with other systems that were reported in the literature is its modularity in the hardware structure as well as in the knowledge base that is integrated, facilitating extensibility with new sensors and new rules. Moreover, the system is simple, easy to be developed and has a minimal cost while having a good efficiency. Also, the ontology that was developed facilitates the integration of the intelligent system in drinking water quality monitoring networks based on intelligent agents or multi-agent systems where real time communication between subsystems is essential.

CONCLUSION

The paper presented an Arduino-based intelligent system for drinking water quality analysis. The system applies a knowledge based approach that was detailed, starting with the development of a conceptual model of drinking water quality analysis under the form of an ontology, and continuing with the design and implementation of a knowledge base for drinking water quality analysis.

The experimental system included a pH sensor, an Arduino UNO microcontroller and a Raspberry Pi microprocessor on which the knowledge base was integrated, and it was tested on different types of drinking water samples, providing good results that revealed its efficiency and easy to use capability. The solution adopted for the development of the system's hardware was a simple one, minimizing the cost but keeping the efficacy of the analysis that is performed on different types of drinking water (tap and bottled) with a set of inference rules.

As a future work, the system will be enhanced in order to perform a more comprehensive analysis of drinking water quality by adding more sensors (e.g. turbidity sensor, hardness sensor), and extending the knowledge base with new rules (heuristic rules, WQI computation rules, standard's rules) related to the new measured parameters included in the analysis. The improved system could be integrated in a multi-agent system, geographically distributed, that monitors, analyzes and predicts in real time the drinking water quality in a larger urban area comprising also the drinking water sources (e.g. a lake with its water treatment station).

REFERENCES

- [1] N. F. Gray, "Drinking water quality: Problems and Solutions", 2nd edition, Cambridge University Press, 2008.
- [2] A. Manna, D. Biswas, "Assessment of drinking water quality using water quality index: a review", *Water Conservation, Science and Engineering*, 8:6, 2023.
- [3] S. Chidiac, P. E. Najjar, N. Onaini, Y. E. Rayess, and D. E. Azzi, "A comprehensive review of water quality indices (WQIs): history, models, attempts and perspective", *Rev. Environ. Sci. Biotechnol.*, vol. 22, pp. 349-395, 2023. <https://doi.org/10.1007/s11157-023-09650-7>.
- [4] I. Păun, L. Cruceru, F. L. Chiriac, M. Niculescu, G. G. Vasile, N. M. Marin, "Water quality indices – methods for evaluating the quality of drinking water", *Proceedings of the 19th INCD ECOIND International Symp – SIMI 2016 "The Environment and the Industry"*, Bucharest, Romania, 12-14 October 2016, pp. 395-402. <https://doi.org/10.21698/simi.2016.0055>.
- [5] E. M. Marica, "Design and implementation of a knowledge based system for drinking water quality analysis", Diploma Project, Department of Automatic Control, Computers and Electronics, Petroleum-Gas University of Ploiesti, 2024.
- [6] EU Drinking Water Directive DWD 2020/2184 https://environment.ec.europa.eu/topics/water/drinking-water_en
- [7] Romanian Drinking Water Regulations Ordinance No 7/2023 <https://www.asro.ro/lista-standarde-calitatea-apei/>
- [8] S. Palabiyik, T. Akkan, "Evaluation of water quality based on AI: performance of multilayer perceptron neural network and multiple linear regression versus water quality indexes", *Environment, Development and Sustainability*, Springer, 2024. <https://doi.org/10.1007/s10668-024-05075-6>.
- [9] M. B. Addisie, "Evaluating drinking water quality using water quality parameters and esthetic attributes", *Air, Soil and Water Research*, vol. 15, pp. 1-8, 2022.
- [10] S. K. Priya, G. Shenbagalakshmi, T. Revathi, "Architecture of smart sensors for real time drinking water quality and contamination detection in water distributed mains", *Romanian Journal of Information, Science and Technology*, vol. 22, no 3-4, pp. 202-214, 2019.
- [11] M. A. Islam, S. C. Roy, M. F. U. Utsho, L. Naznin, R. Sarkar, R. R. Sarkar, "An IoT-enabled intelligent water quality monitoring system for tourist safety using machine learning", *Discover Electronics*, 2:28, 2025.
- [12] P. Khatri, K. K. Gupta, R. K. Gupta, "Raspberry Pi-based smart sensing platform for drinking-water quality monitoring system: a Python framework approach", *Drinking Water Engineering and Science*, 12, 31-37, 2019. <https://doi.org/10.5194/dives-12-31-2019>.
- [13] A. Tiri, L. Belkhir, L. Mouni, "Evaluation of surface water quality for drinking purposes using fuzzy inference system", *Ground Sustainable Development*, 6, 235-244, 2018.
- [14] V. Lakshmikantha, A. Hiriyannagowda, A. Manjunath, A. Patted, J. Basavaiah, A. A. Anthony, "IoT based smart water quality monitoring system", *Global Transitions Proceedings*, 2, 181-186, 2021. <https://doi.org/10.1016/j.gltp.2021.08.062>.
- [15] M. A. Murti, A. R. A. Saputra, I. Alinursafa, A. N. Ahmed, A. Yafouz, A. El-Safie, "Smart system for water quality monitoring utilizing long-range-based Internet of Things", *Applied Water Science*, 14:69, 2024.
- [16] T. Hiu, L. Xiujuan, S. Qifa, L. Qiang, K. Zhuang, G. Yan, "Evaluation of Drinking Water Quality using the Water Quality Index (WQI), the Synthetic Pollution Index (SPI) and Geospatial Tools in Lianhuashan District, China", *Pol. J. Environ. Stud.*, vol. 30, no 1, 141-153, 2021. Doi: 10.15244/pjoes/120765.
- [17] K. Raghunath, S. B. Khan, P. Govindarajan, T. R. Mahesh, M. Alojail, T. R. Gadekallu, "Machine learning-driven intelligent water quality assessment for enhanced drinking safety and real-time consumer awareness", *Hydrology Research*, vol. 56, no 2, 136, 2025. Doi: 10.2166/nh.2025.097
- [18] O. O. Ajayi, A. B. Bagula, H. C. Maluleke, Z. Gaffoor, N. Jovanovic, K. C. Pietersen, "WaterNet: A network for monitoring and assessing water quality for drinking and irrigation purposes", *IEEE Access*, 10, 48318-48337, 2022.
- [19] A. A. Amogne, "A comprehensive assessment of drinking water quality using the water quality index", *Water Supply*, vol. 25, no 8, 1235, 2025. Doi: 10.2166/ws.2025.071.
- [20] E. L. F. Lima, M. D. R. Soares, C. R. Maciel, M. A. G. Simão, L. V. M. Cavalcante, H. S. Noguchi, F. R. do Nascimento, "Assessment of water quality for human consumption in the municipality of Manicoré-am", *Scientific Reports*, 15: 10248, 2025.
- [21] S. Machona, G. M. Ogendi, B. S. Ahana, "Assessment of groundwater quality for drinking using the water quality index", *Water Quality Research Journal*, vol. 60, no 1, 151, 2025. Doi: 10.2166/wqrj.2025.047.
- [22] K. Olatunde, S. K. Patton, M. York, J. Igboanugo, "Public perception of drinking water quality in the United States: A Thirty-Three Year (1990-2023) Systematic Review of Primary Research Articles", *American Journal of Water Research*, vol. 13, no 2, 26-50, 2025.
- [23] M. Cioroi, A. Ene, "A study on drinking water quality in South East Romania", *Annals of "Dunarea de Jos" University of Galati, Fascicle II, Year XII(XLIII)*, no 2, 2020.
- [24] C. Radulescu, P. Bretcan, A. Pohoata, D. Tanislav, R. M. Stirbescu, "Assessment of drinking water quality using statistical analysis: a case study", *Romanian Journal of Physics*, vol. 61, nos 9-10, pp. 1604-1616, 2016.
- [25] P. Qian, G. Liu, "Application of high-frequency intelligent sensing network in monitoring and early warning of water quality dynamic change", *International Journal of Computational Intelligence Systems*, 17:195, 2024.
- [26] L. Manjakkal, S. Mitra, Y. R. Petillot, J. Shutler, E. M. Scott, M. Willander, R. Dahiya, "Connected sensors, innovative sensor deployment and intelligent data analysis for online water quality monitoring", *IEEE Internet of Things Journal*, vol. 8, no 18, pp. 13805-13824, 2021.
- [27] P. R. Wyrwoll, A. Manero, K. S. Taylor, E. Rose, R. Q. Grafton, "Measuring the gaps in drinking water quality and policy across regional and remote Australia", *npj Clean Water*, 5:32, 2022.
- [28] Protégé ontology editor: <https://protege.stanford.edu/> Accessed: October 30, 2025.
- [29] Arduino UNO: <https://docs.arduino.cc/hardware/uno-rev3/> Accessed: June 30, 2024.
- [30] Raspberry Pi: <https://www.raspberrypi.com/documentation/> Accessed: June 30, 2024.
- [31] pH Sensor: <https://github.com/nthnn/PH4502C-Sensor> Accessed: May 15, 2024.